

DIM Design & Installation Manual

Swisspearl large panels and Linearis slat panels



| | | | | |
|-----------------------------------------------------------|--------------------------------------------------------------------|-----------------------------------------------------------------------|----------------|----|
| General information, Program | | Remarks, system, validity, ordering material, rain screen cladding | 3 | |
| | Panel sizes | Overview panel sizes | 4 | |
| | | Application cutting | 5 | |
| | Reflex | Appearance Reflex, arrows to rear face | 6 | |
| | | Ordering material, Software support, Positioning, Cutting from CAD | 6-7 | |
| | Adhesive | Adhesive application | 7 | |
| | Bending radius | Portrait / Landscape | 8 | |
| | Accessories | Fasteners | 9 | |
| | Design | General remarks | Joint material | 10 |
| | | | Terminology | 11 |
| Corner zone, Application, Windload | | | 12 | |
| Insulation, Rear ventilation, Open joints | | | 12 | |
| Ventilation openings, building dilatation | | | 12 | |
| Panel support, Compatibility, Sub-frame | | | 13-14 | |
| Distances to panel edge, joints, fixed and sliding points | | | 15 | |
| Metal panel support | | Aluminum, steel sub-frame | 16-17 | |
| | | Drilling and riveting, fixed point, sliding point, fastener distances | 18 | |
| | | Windload guidelines | 19-22 | |
| | | Single span panel | 23 | |
| | | Swisspearl portrait/landscape | 24-26 | |
| | | Fastening layout stripes | 27-29 | |
| Details | | Outer corner, Inner corner, Window jamb, window sill | 30-32 | |
| Linearis | | Window head, bottom detail, coping detail | 33-35 | |
| Timber panel supports | | Distances to panel edge, panel joints | 36 | |
| | | Timber quality, screws, ventilation cavity | 37 | |
| | Horizontal section, vertical joints at windows, fastener distances | 38-39 | | |
| | Windload guidelines | 40-43 | | |
| | Single span panels, Installation | 44 | | |
| | Swisspearl portrait/landscape | 45 | | |
| | Fastening layout stripes | 46-49 | | |
| Installation | Details | Outer corner, Inner corner, Window jamb, window sill | 50-52 | |
| | | Window head, bottom detail, coping detail | 53-56 | |
| | Storage on site | On site storage, Guideline, Stacking | 56 | |
| | Cutting, Tools | Fabrication, Cut outs, Sealer, tools | 57 | |
| | Cleaning | Cleaning procedures, Masking tape | 58 | |

Remarks

Remarks

This DIM (Design + Installation Manual) provides technical information regarding design and installation. Refer to area manager and local distributor for further information such as:

- Terms of delivery
- Pricing
- Products and colors
- Lead time, etc.

More general information available on www.swisspearl.com

CH- 8867 Niederurnen
Tel. +41 55 617 11 60
Email: info@swisspearl.com

Validity of DIM

Please consult your local distributor and or the Technical Advisor prior to the commencement of shop drawings or installation for the most current DIM guide. The current DIM can always be found at www.swisspearl.com. All previous DIM guides should be disregarded and are no longer valid

Product warranty

10 year warranty for the functional quality of panels and accessories, provided that the installation is in full compliance with this DIM.

Advantages of fiber cement products

- Maximum protection against weather
- Excellent longevity
- Easy installation in any climate
- Almost no maintenance required
- Proven details
- No cracks, paint or sealant problems
- High sustainability
- Non combustible

Project specific ordering

Subtle visual differences may occur between product batches. Therefore we recommend ordering by job or specific elevation if ordering in phases.

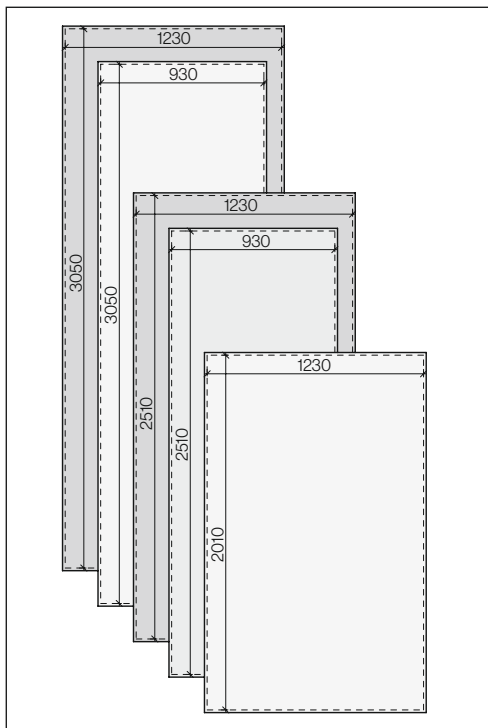
Overview panel sizes

8 mm & 12 mm thick panels - max. net panel sizes

Overview

| Swisspearl | | Nobilis | Zenor | Carat Reflex Avera Incora | Carat Reflex | Kandor |
|------------------|-----------------------------|-----------|-------|------------------------------------|-----------------|--------|
| Thickness | mm | 8/12 | 8 | 8 | 12 | 8 |
| Weight | ca. kg/m ² | 15.7/24.6 | 15.7 | 15.7 | 24.6 | 15.7 |
| Format | mm | | | | | |
| Untrimmed panels | max. net panel sizes | | | | | |
| 3070×1250 | 3050×1230 | ■ | ■ | ■ | ■ | |
| 2530×1250 | 2510×1230 | ■ | ■ | ■ | ■ | |
| 2030×1250 | 2010×1230 | ■ | | | | |
| 3070×950 | 3050×930 | ■ | | * | | |
| 2530×950 | 2510×930 | ■ | | * | | |
| 3020×1270 | 3000×1250 | | | | | ■ |

* Panels with 930 mm width are only available in CARAT colors Agate, Black Opal, Coral, Crystal, Sapphire and Topaz and require a minimum order quantity of 500 panels. Avoid to mix the two widths. Base sheets in width 1230 and 930 mm are manufactured as different production batches so that the shade may deviate

Product data

- Density > 1.75g/cm³
- Modulus of elasticity ca. 15'000 MPa
- Design resistance for bending ca. 8.0 MPa
- Thermal expansion coefficient 0.01 mm / m / °K
- Fire classification according to EN 13 501-1 & A2-s1, d0
- Frostresistance and durability under EN 12467
- Thermal range - 40°C to + 80°C

HR coating

Special coating with increased scratch and UV resistance that allows removal of graffiti using Acetone. Availability as per Program and Colors.

F-coating for façade

For inclined cladding, panels with F-coating cater for increased exposure to weathering. It is opaque and matched to standard finishes, and has higher UV resistance.

R-coating for roof

Roofing panels must have minimum fall of 6° (10.5%). R-coating is opaque and matched to standard finishes, and has higher UV resistance. The panels in the color ranges Amber and Onyx are supplied with standard grey panel core.

Application

Swisspearl panels can be attached to vertical timber or metal profiles. Suitable for new facades or existing cladding renovations.

Untrimmed full size panels

Untrimmed panels will only be provided to approved fabricators.

Signage, light fittings, etc.

Provide structural attachment points behind the panel as required. Leave generally min. 6 mm (¼") free gap between panel edge and installation - so as not to constraint the panel movement. Light weight letters may be glued onto panel surface, do not span any letters between panels.

Net Sizes

Untrimmed Swisspearl panels must be trimmed 10 mm on all four sides.

Sealed cut edges

All panel edges cut on site or at fabricators workshop must be sealed by LUKO sealer, provided by Swisspearl.

Installation Reflex

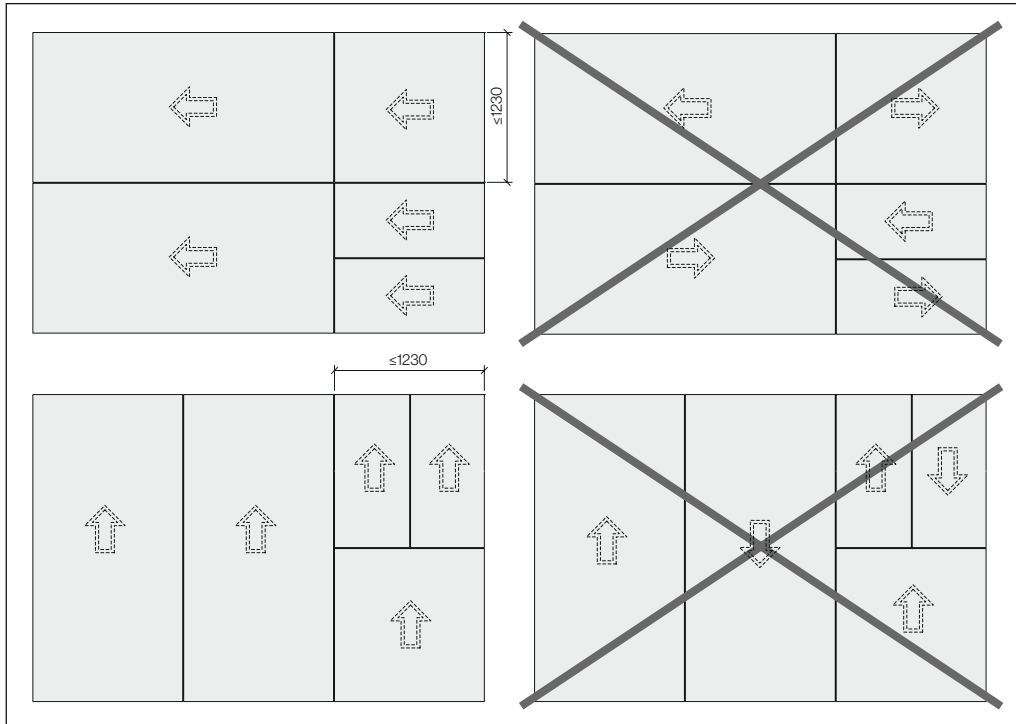

When installed all the arrows to Reflex panels must point in one and same direction.

Landscape orientation
All arrows to the left

Portrait orientation
All arrows up

Cutting CAD drawing
 Regarding panel fabrication at the factory based upon CAD drawings as for odd panel shapes, perforations etc.:
 Arrows must be indicated on the drawings to all panels. Panels always shown as seen on building elevation (finished face).

Panels are shown as on building elevation (finished face).

Adhesive application

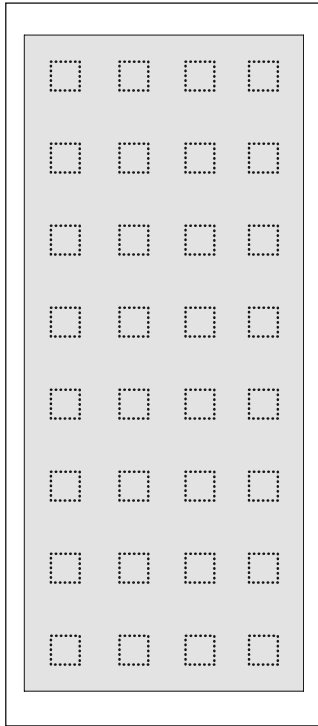

Adhesive technology

Specially ordered ARSB panels are signified by printed squares on the backside of the panel. Please consult with your adhesive manufacturer prior to installation.

General requirements

Glue manufacturer's instructions for use must be strictly followed regarding all aspects, including:

- Cleanliness of panels and support profiles
- Panel and air temperature
- Air moisture content
- Etc.

Support profiles

- For exterior application the panels may be glued to aluminium supports only.
- Sub framing to be approved by glue manufacturer prior to stating the installation.

Panel ordering

Panels ordered for adhesive application are called ARSB and are available upon request at time of order. Standard Swisspearl panels cannot be used for adhesive application.

Warranty

Panel manufacturer provides functional warranty for the panels only. Warranty for the attachment of the panels to be obtained by glue manufacturer.

Swisspearl 8 mm portrait

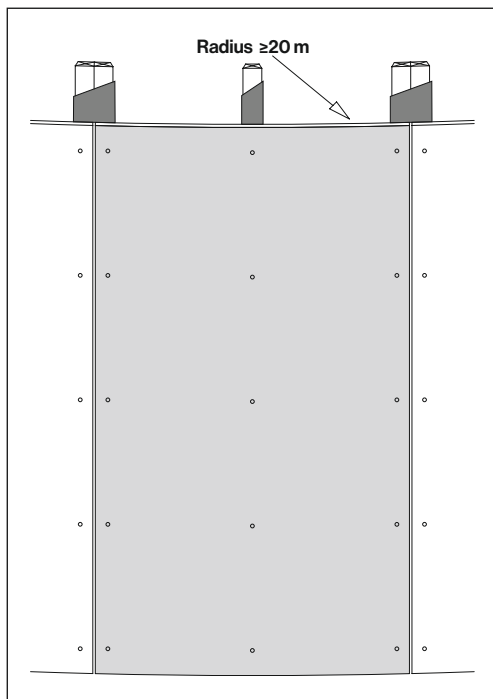

Portrait panels, attached to vertical supports.
Minimum radius = 20 m. The support must be fixed with 2 screws per fixing point.

Swisspearl 8 mm landscape

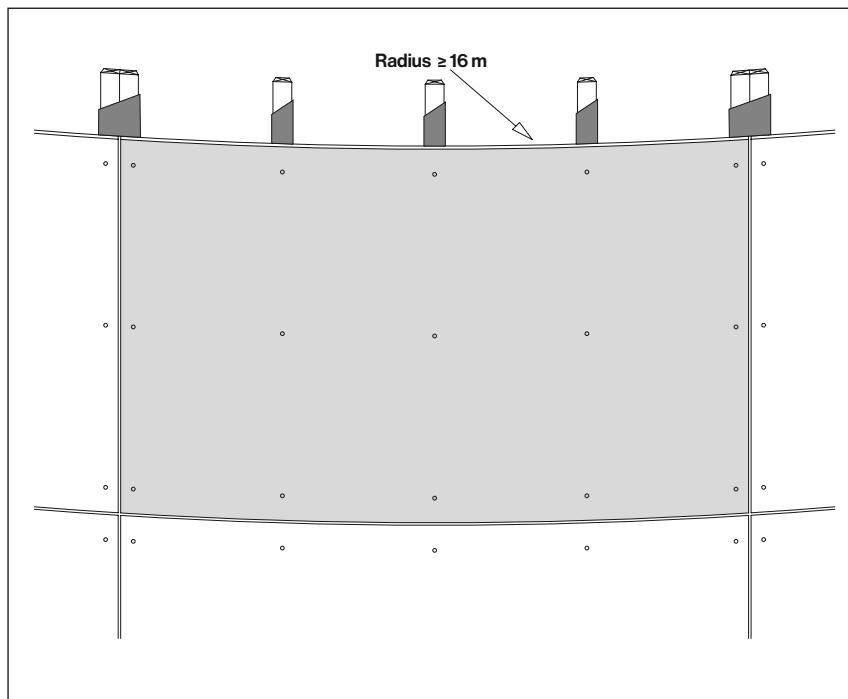

Landscape panels, attached to vertical supports at max. 600 mm centers.
Minimum radius = 16 m. The support must be fixed with 2 screws per fixing point.

Fasteners

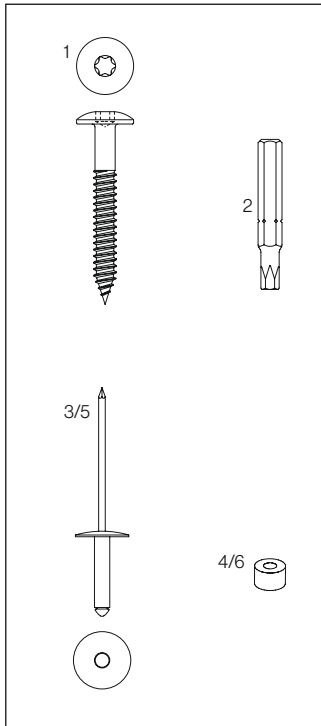

To timber battens

- 1 Screw, inox, saucer head \varnothing 12 mm, T20 drive, blank or powder coated
4.8×30, 4.8×38 mm
4.8×44, 4.8×60 mm
- 2 Torx bit T 20 W

To aluminium profiles

- 3 Aluminium rivet head \varnothing 15 mm, blank or powder coated
 - 4.0×18-K15, 8-13 mm grip range
 - 4.0×24-K15, 13-18 mm grip range
 - 4.0×30-K15, 18-23 mm grip range
- 4 Fixed point sleeve aluminum type 8

To steel profiles

- 5 Stainless steel rivet, head \varnothing 15 mm, blank or powder coated
 - 4.0×18-K15, 9-14 mm grip range
 - 4.0×23-K15, 14-19 mm grip range
- 6 Fixed point sleeve stainless steel type 8

Maritime conditions

Maritime conditions call the use for stainless steel rivets. Those may be used on steel or anodized aluminum sub frame. Maritime conditions are considered within a distance of 1 km (0.6 miles) from the sea. Material specification for sub frame, fasteners and accessories to cater for maritime conditions according to local standards.

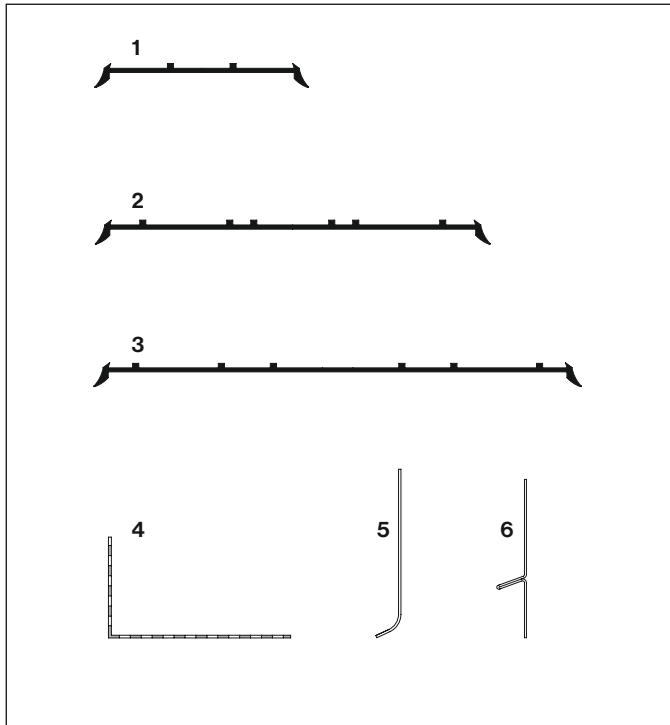
Joint material

- 1 EPDM band, black, 60 mm wide for intermediate supports with side lips, in 50m rolls
- 2 EPDM band, black, 100 & 120 mm wide for butt joints with side lips, in 50m rolls
- 3 EPDM band, black, 150 mm wide for inner and outer corners with side lips, in 25m rolls
- 4 Ventilation profile, raw aluminum or standard colors, 50x30 mm, 70x30 mm, 100x40 mm, 2510 mm long, 0.6 mm thick
- 5 L-flashing, stainless steel, millor powder coated, 0.5 mm thick 2510 / 3050 mm long
- 6 Horizontal joint flashing, aluminium, powder coated black, 0.5 mm thick 2510 / 3050 mm long

Terminology

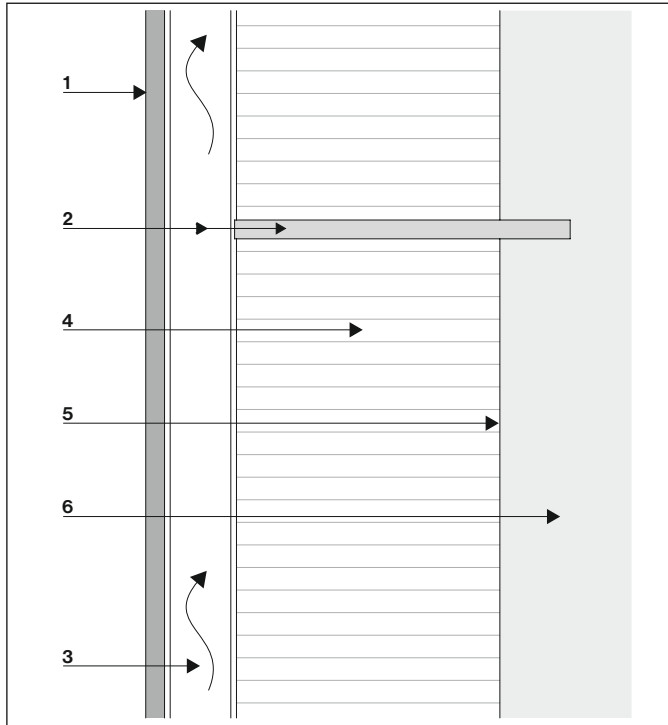

Vertical section

Rear ventilated cladding

The design principle involves the deflection (screening) of the rain water. As the panel joints are not sealed, minimal amounts of water can gain access into the air cavity behind the panel. The cavity is naturally ventilated by vent gaps at bottom and top, so that any moisture will evaporate naturally by thermal action.

Cladding (1)

Panels with open or closed joints, in one plane or lapped.

Sub framing (2)

To support the cladding dead and wind load generally vertical panel supports in timber or metal.

Ventilation cavity (3)

Cavity behind panel with ventilation gaps at bottom and top.

Thermal insulation layer (4)

To increase the thermal insulation capacity of the exterior wall.

Substrate (5)

Face of exterior wall, such as plaster, concrete, exterior sheathing, wind proofing layer, etc.

Exterior wall (6)

Brick, concrete, wood and steel studs

Corner zone

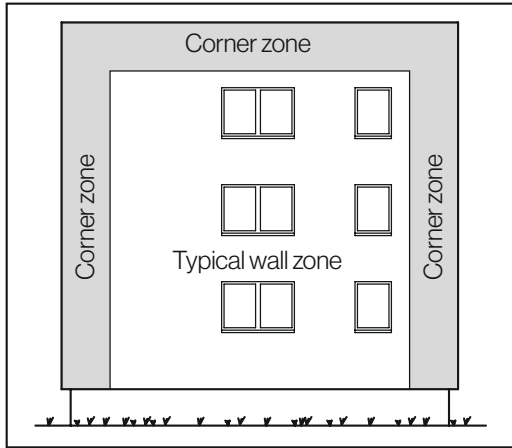

Wind load zones
 As per scheme there are two wind load zones: The corner zones generally are subject to increased negative wind load (suction) due to turbulence at the edges of the building. The applicable wind load values must be determined in the cladding specification.

Recommended manufacturer cavity depth:

| Cladding height | min. cavity |
|-----------------|-------------|
| < 6 m | 20 mm |
| 6 - 15 m | 25 mm |
| 15 - 25 m | 30 mm |
| 25 - 50 m | 40 mm |
| 50 - 75 m | 50 mm |
| 75 - 100 m | 75 mm |
| > 100 m | 100 mm |

Application

Swisspearl cladding panels can be attached to vertical supports made of timber, aluminium or steel.

Windload

Always consider local standards when determining panel fastener differences. This is especially important for tall buildings, for buildings with special shapes and for high wind exposure areas.

Ventilation cavity

Building tolerances must be allowed for. The cavity may not be reduced by horizontal profiles or any stray objects such as loose wind proofing layers, etc.

Ventilation cavity on vertical profiles

Building tolerances must be allowed for. The cavity may not be reduced by horizontal profiles or any stray objects such as loose wind proofing layers, etc.

Building expansion joints

The buildings structural expansion joints should be considered when designing subframe systems. Structural expansion joints must be applied to sub frame and cladding as provided to the building structure.

Ventilation gaps

Min. ventilation gap to be 20 mm.

Open panel joints

When joints are left open to weather, cavity thickness to be min. 40 mm.

Ventilation cavity

Min ventilation cavity to be 20 mm with a vertical airflow of 100%.

Ventilation cavity with perforated horizontal profiles

Min ventilation gap to be 40 mm. Horizontal profiles should allow min. 75% airflow. In advance please contact your Technical Service for approval.

Panel support

Panel must be supported on an even surface. If perforated angles are placed between the panel and batten/vertical profile the closure piece must not exceed 0.8 mm. Perforated angles have to allow ventilation entrance with a min. perforation of 60%. The use of an aluminium mesh is possible. It has a high ventilation ratio, thin material thickness (no push out of panel) and is easy to install.

Material compatibility

Untreated aluminum material such as Window sills, frames, etc. is not compatible with cement and must be protected against dust from drilling panels, etc. Aluminum components are to be used in anodized or powder-coated quality for exterior applications with protective films.

- 1 Swisspearl panel
- 2 Fastener
- 3 Panel support
- 4 Perforated angle
- 5 Recess

Timber battens

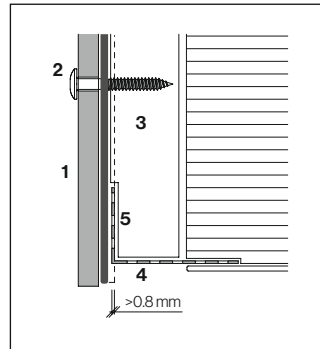

Metal profile

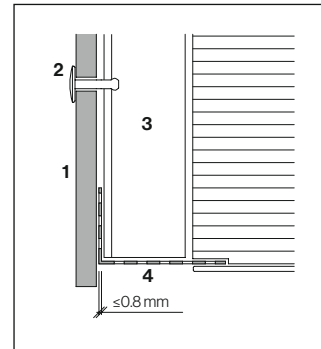
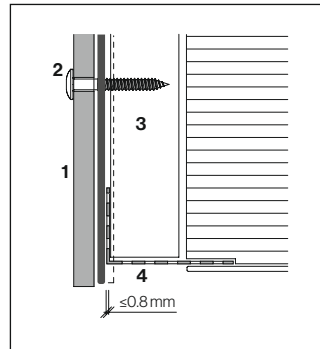
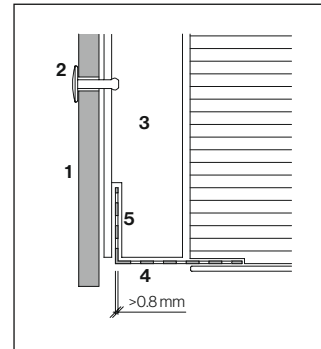

Sealant material

Generally to keep the cladding maintenance free the use of sealants should be avoided. Where the use of sealant is unavoidable Polyurethane, Acrylic or Hybrid Polymer products would be best suitable. Before applying any sealant to fiber cement material the compatibility must be checked as certain materials leave permanent staining on panel surface.

Sub frame types

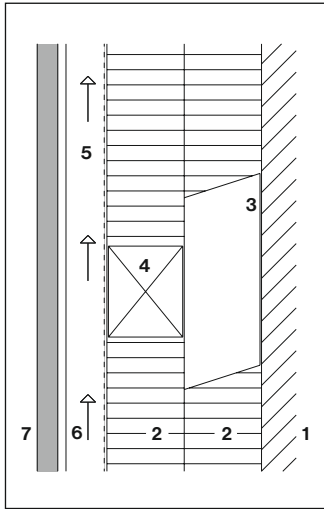

Timber / timber

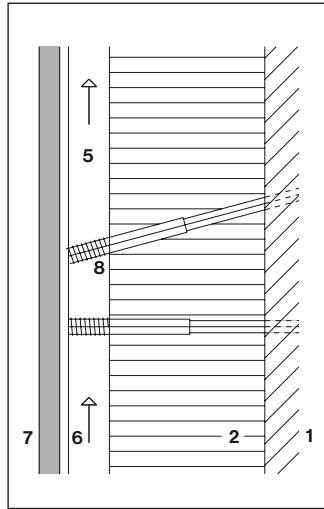

Timber / spacer screw

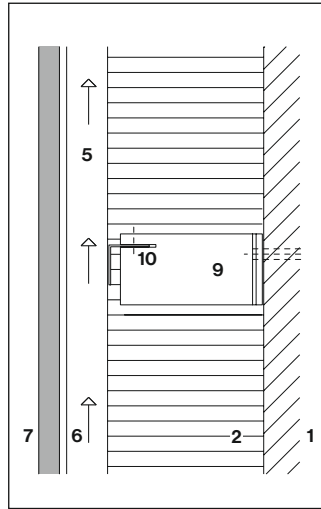

Metal / timber verticals

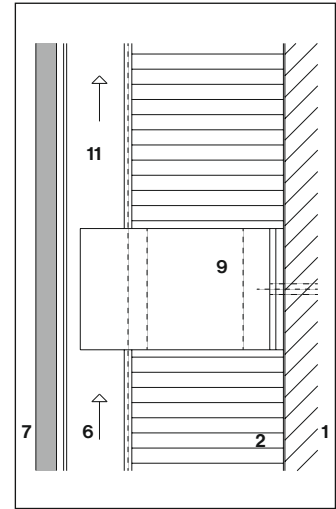

Metal

- 1 Substrate
- 2 Thermal insulation
- 3 Vertical batten
- 4 Horizontal batten
- 5 Panel support
- 6 Vent cavity
- 7 Swisspearl

- 8 Spacer screw
- 9 Bracket
- 10 Horizontal batten
- 11 Vertical batten

Swisspearl rivet

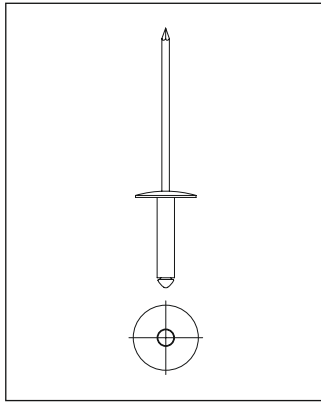

Swisspearl rivet: Ø 15 mm 4.0×18-K15

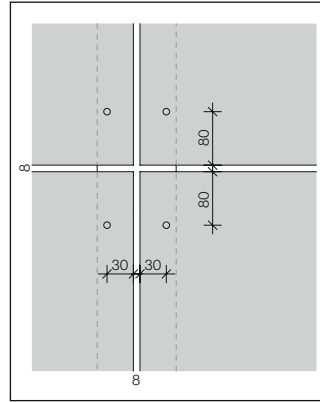

Panel edge distances

Holes in panel for rivets

Diameter 9.5 mm

Standard edge distances

Horizontally 30 mm

Vertically 80 mm

Minimum edge distances

Horizontally 30 mm

Vertically 60 mm

Maximum edge distance

Horizontally and vertically 100 mm

Panel joints

Typical panel joint is 8 mm, this allows panel scraps to be used as spacers. Wider joints will make any inaccuracies in the installation less noticeable.

Fixed, slipping points

Each panel must be fastened by 2 fixed points in the panels center to support the panels deadload. All other rivets are sliding points.

Drill holes Ø 4.1 mm to metal profiles

Use centering drill gauge so the holes will be concentric to the Ø 9.5 mm hole in the panel. Use drill bit type A for aluminum profiles and type S for steel.

Sub-frame engineering

Engineer / contractor is responsible for the design and installation of all sub frame parts including all pertaining fasteners.

The slipping point connection is **NOT** meant to accommodate building drift or seismic movement.

Aluminium profiles

Aluminum thickness should be a min. of 2 mm. Profiles should not exceed 3 m and profile breaks should coincide with panel joints.

Aluminium rivet

4.0 x 18 - K15 rivet, head Ø 15 mm, powder coated or blank, grip range 8 - 13 mm.

Staggered horizontal panel joints

Use two vertical profiles to vertical panel joint so that each can be broken on its horizontal panel joint level.

Black panel joints

Panel joints read as shadow lines. It is recommended to blacken the metal where visible, with paint or PVC paint tape.

Steel profiles

Steel panel supports to be min. gauge 18 (1.27 mm / 0.05") to obtain nominal pull out value. Profiles should not be longer than 6 m (20').

Stainless steel rivet

4.0 x 18 - K15 rivet, head Ø 15 mm, powder coated or blank, grip range 9 - 14 mm.

Sub-frame engineering

Engineer / contractor is responsible for the design and installation of all sub frame parts including all pertaining fasteners.

Horizontal joint

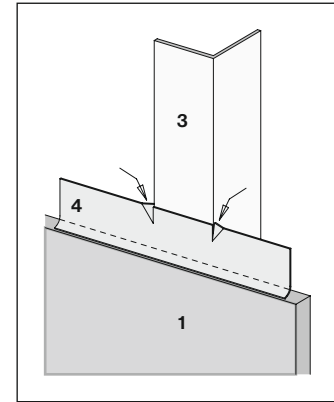
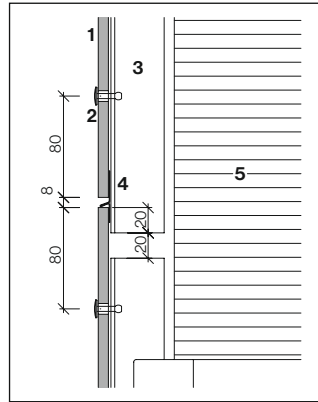

- 1 Swisspearl panel 8 mm
- 2 Rivet
- 3 Panel support profile
- 4 Joint flashing (optional).
L = panel width - 2 mm.
- 5 Thermal insulation

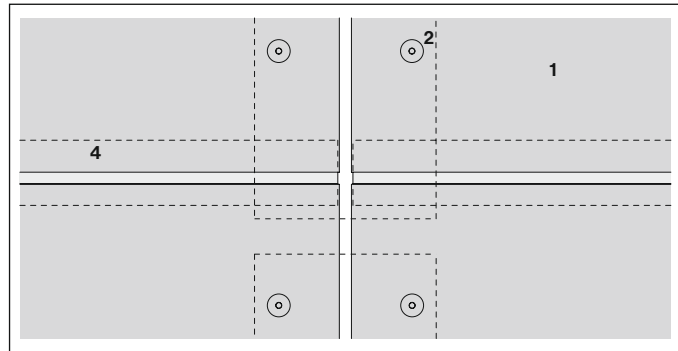

Any breaks to panel support profiles must be located at panel joints as shown. Flashing cut at one vertical as shown to prevent lateral dislocation of flashing.

Horizontal section

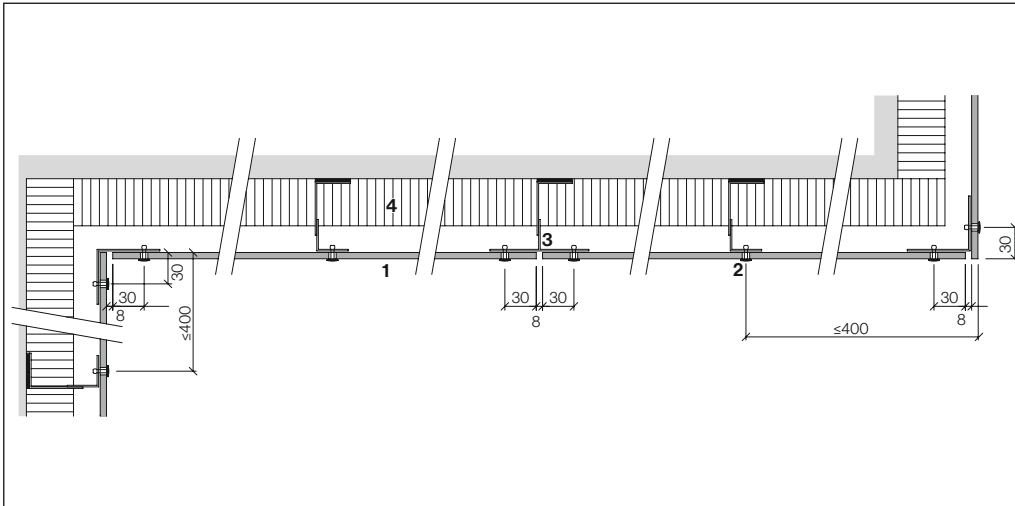

Panel may be cantilevered max. 400 mm.

- 1 Swisspearl panel 8 mm
- 2 Rivet
- 3 Aluminum profile
- 4 Thermal insulation

Rivet installation

Use rivet gun GESIPA ACCUBIRD or similar. Do not use pneumatic equipment. Use centering drill gauge with drill bit Ø4.1 mm to obtain concentric hole [A/3].

Fixed point for Aluminum Sub-frame

Fixed point for Aluminum, Type 8 Ø9.4 mm [B/4]

- Rivet head Ø15 mm 4.0×18-K15, blank or powder coated, grip range 8-13 mm

Fixed point for Steel Sub-frame

Fixed point steel A2, Type 8, Ø9.4 mm [B/4]

- SS Rivet, head Ø15 mm, 4.0×18-K15, blank or powder coated, grip range 9-14 mm

Each panel must be fastened by 2 fixed fastening points in the panel center, installed first. All the others are slipping points.

Slipping points for Aluminum Sub-frame

Use centering drill gauge with drill bit Ø4.1 mm to obtain concentric hole [C/5]

- Alu Rivet, head Ø15 mm 4.0×18-K15, blank or powder coated, grip range 8-13 mm. Slipping points for Steel Sub-frame use centering drill gauge with drill bit Ø4.1 mm to obtain concentric hole [C/5]

Slipping points for Steel Sub-frame

- Slipping points for Steel Sub-frame. Use centering drill gauge with drill bit Ø4.1 mm to obtain concentric hole [C/5]
- SS Rivet, head Ø15 mm, 4.0×18-K15, blank or powder coated, grip range 9-14 mm

- 1 Support profile
- 2 Swisspearl panel 8 mm
- 3 Centerer drill gauge
- 4 Fixed point sleeve, type 8
- 5 Rivet 4.0 x 18 - K15

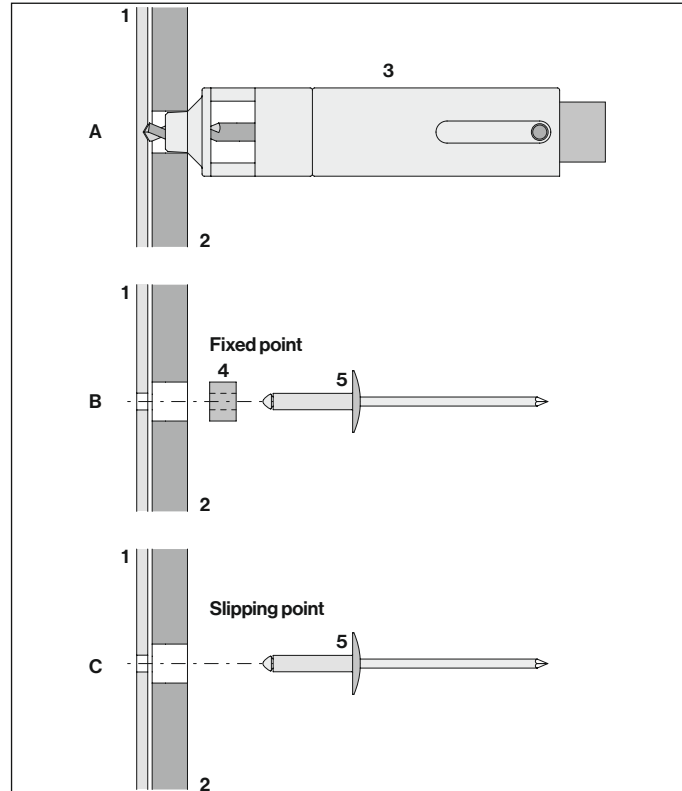

Metal sub frame - 8 mm façade panels - rivet distances

| Characteristic value of wind suction (according to European standards) | | Design value of wind suction (with a safety coefficient of 1.5) | | Spacing d (maximal distance between rivets) | | | |
|---------------------------------------------------------------------------------|--------|--------------------------------------------------------------------------|--------|---------------------------------------------|------------------|------------------------------|------------------|
| | | | | Vertical panel (portrait) | | Horizontal panel (landscape) | |
| kN/m ² | psf | kN/m ² | psf | horizontally mm | vertically mm | horizontally mm | vertically mm |
| -0.70 | -13.90 | -1.0 | -20.9 | 600 | 725 | 725 | 530 |
| -1.00 | -20.90 | -1.5 | -31.3 | 600 | 590 | 675 | 530 |
| -1.30 | -26.50 | -1.9 | -39.7 | 600 | 490 | 520 | 530 |
| -1.80 | -37.60 | -2.7 | -56.4 | 400 | 490 | 430 | 370 |
| -2.30 | -48.70 | -3.5 | -73.1 | 400 | 420 | 400 | 370 |
| -2.70 | -55.70 | -4.0 | -83.5 | 400 | 330 | 370 | 370 |
| -3.30 | -69.60 | -5.0 | -104.4 | 300 | 370 | 370 | 280 |
| -4.00 | -83.50 | -6.0 | -125.3 | 300 | 330 | 330 | 220 |

Above table is a guide line for 2 or more fasteners in vertical and horizontal direction. The spacings have been calculated considering a safety factor of 1.5. The spacings originate from 1230x3050 mm full size panels with equal distances between rivets. Data may be interpolated.

Metal sub frame - 8 mm façade panels - rivet distances**Engineering responsibility**

The spacings in above table are provided as indication. For the actual cladding design a locally licensed engineer shall assume responsibility for calculation and verification.

Panel data

- Modulus of elasticity
MOE ca. 15'000 MPa
- Modulus of rupture
(characteristic)
MOR (average) > 22 MPa
- Design value bending
resistance 8.0 MPa
(2.5 safety factor)
- Density > 1.75g/cm³

Design values**Resistance of aluminum and steel rivets 4.0x18 K15**

| Position | Distance between fasteners (spacing) | | |
|----------|--------------------------------------|--------|--------|
| | 720 mm | 600 mm | 400 mm |
| Middle | 774 N | 821 N | 864 N |
| Edge | 399 N | 481 N | 575 N |
| Corner | 254 N | 311 N | 414 N |

The data was evaluated according to ETAG 034 using 8 mm panel, and includes a safety factor of 2.5. Diameter of panel hole must be 9.5 mm, and rivet head must be 15 mm. Min. thickness for steel profiles to be 1.27 mm, and 2 mm for aluminum. Edge distances 30 mm horizontally, 80 mm vertically. The data may be interpolated.

Metal sub frame - 12 mm façade panels - rivet distances

| Characteristic value of wind suction (according to European standards) | | Design value of wind suction (with a safety coefficient of 1.5) | | Spacing d (maximal distance between rivets) | | | |
|---------------------------------------------------------------------------------|---------|--------------------------------------------------------------------------|---------|---------------------------------------------|------------------|------------------------------|------------------|
| kN/m ² | psf | kN/m ² | psf | Vertical panel (portrait) | | Horizontal panel (landscape) | |
| | | | | horizontally mm | vertically mm | horizontally mm | vertically mm |
| 2.08 | 43.44 | 3.12 | 65.16 | 570 | 725 | 725 | 570 |
| -2.31 | -48.31 | -3.47 | -72.47 | 570 | 670 | 670 | 570 |
| -2.88 | -60.15 | -4.32 | -90.22 | 570 | 565 | 565 | 570 |
| -3.39 | -70.73 | -5.08 | -106.09 | 570 | 480 | 480 | 570 |
| -4.22 | -88.13 | -6.33 | -132.20 | 570 | 385 | 385 | 570 |
| -5.10 | -106.51 | -7.65 | -159.77 | 380 | 725 | 725 | 380 |
| -7.09 | -148.00 | -10.63 | -222.00 | 380 | 375 | 375 | 380 |
| -8.86 | -185.04 | -13.29 | -277.56 | 380 | 300 | 300 | 380 |

Above table is a guide line for 2 or more fasteners in vertical and horizontal direction. The spacings have been calculated considering a safety factor of 1.5. The spacings originate from 1230x3050 mm full size panels with equal distances between rivets. Data may be interpolated.

Metal sub frame - 12 mm façade panels - rivet distances**Engineering responsibility**

The spacings in above table are provided as indication. For the actual cladding design a locally licensed engineer shall assume responsibility for calculation and verification.

Panel data

- Modulus of elasticity
MOE ca. 15'000 MPa
- Modulus of rupture
(characteristic)
MOR (average) > 22 MPa
- Design value bending
resistance 8.0 MPa
(2.5 safety factor)
- Density > 1.75g/cm³

Design values**Resistance of aluminum and steel rivets 4.0x24 K15**

| Position | Distance between fasteners (spacing) | | |
|----------|--------------------------------------|--------|--------|
| | 720 mm | 600 mm | 400 mm |
| Middle | 1723 N | 1884 N | 2132 N |
| Edge | 1101 N | 1148 N | 1541 N |
| Corner | 718 N | 844 N | 1157 N |

The data was evaluated according to ETAG 034 using 8 mm panel, and includes a safety factor of 2.5. Diameter of panel hole must be 9.5 mm, and rivet head must be 15 mm. Min. thickness for steel profiles to be 1.27 mm, and 2 mm for aluminum. Edge distances 30 mm horizontally, 80 mm vertically. The data may be interpolated.

Single span panels

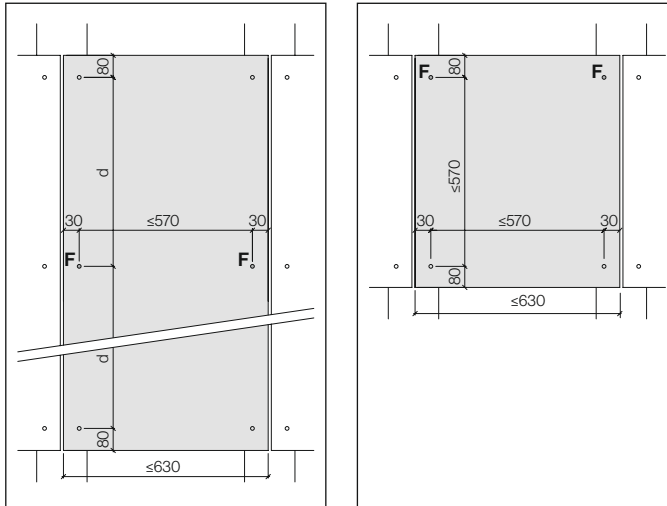

Single span

Fixed point \varnothing 9.5 mm [F]

Slipping point \varnothing 9.5 mm

Soffit panels

Fastener distances for soffit panels and suspended ceilings not to exceed 500 mm.

- Fixed point \varnothing 9.5 mm [F]
- Slipping point \varnothing 9.5 mm

Max. distance between fasteners for single span panels 570 mm, unless smaller distances is required by high wind load as per table of fastener distances.

If more than 5 single span panels are ad- joining each other - the chain of fixed points must be interrupted by a different configuration of the fixed points.

Consult with technical advisor.

Swisspearl vertical panel (portrait)

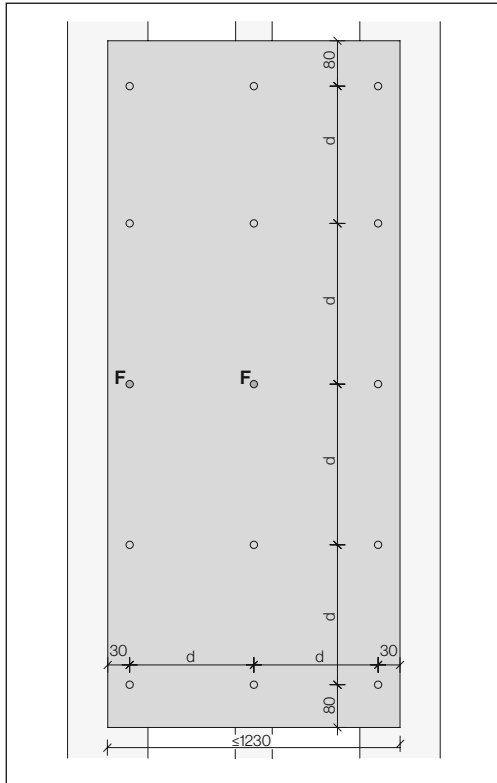

Fixed points [F] center and left.

Swisspearl vertical panel (portrait)

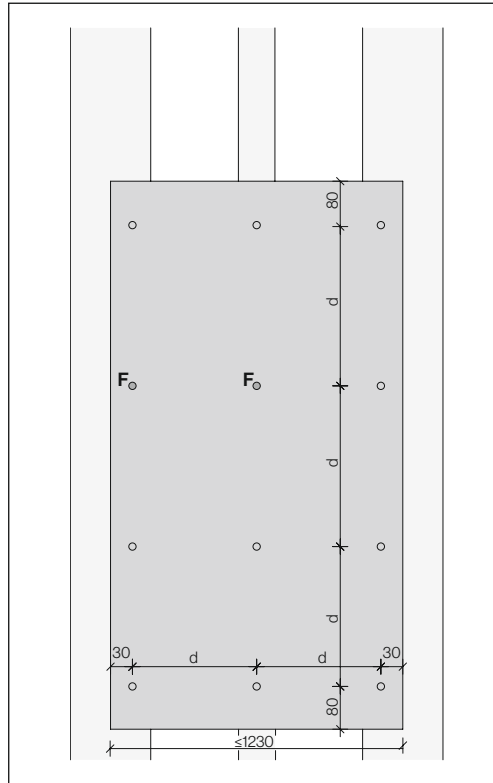

If no rivet at half height go with [F] to row above.

- Fixed point $\varnothing 9.5$ mm [F]
- Slipping point $\varnothing 9.5$ mm

Swisspearl horizontal panel

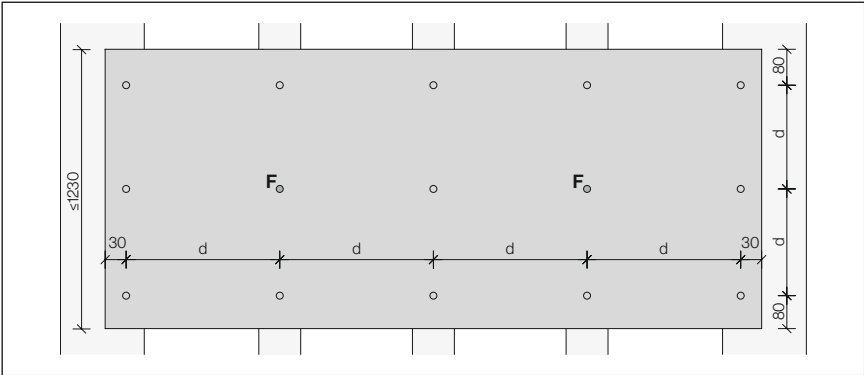

Between fixed points, the max. distance can be 1 slipping point

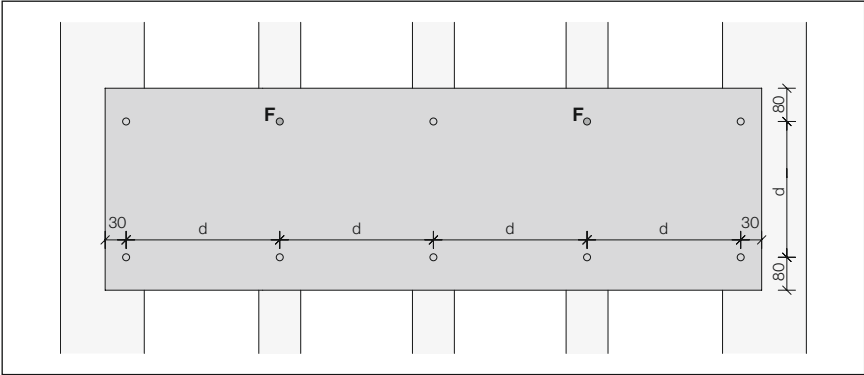

- Fixed point Ø9.5 mm [F]
- Slipping point Ø9.5 mm

Swisspearl horizontal panel (landscape)

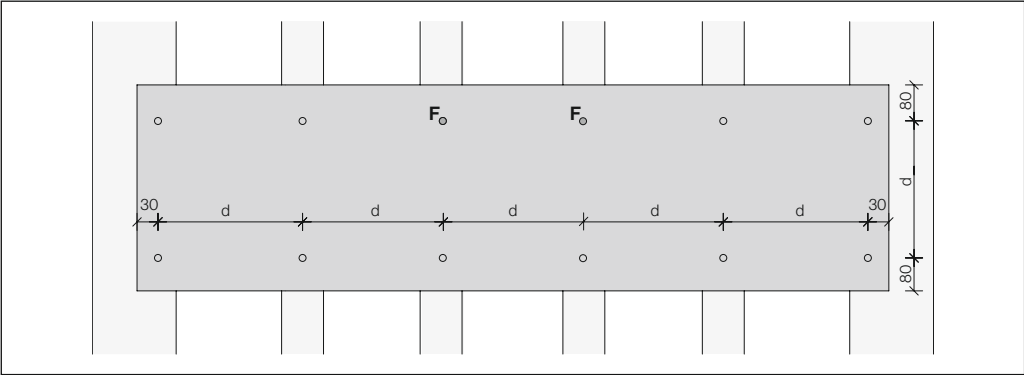
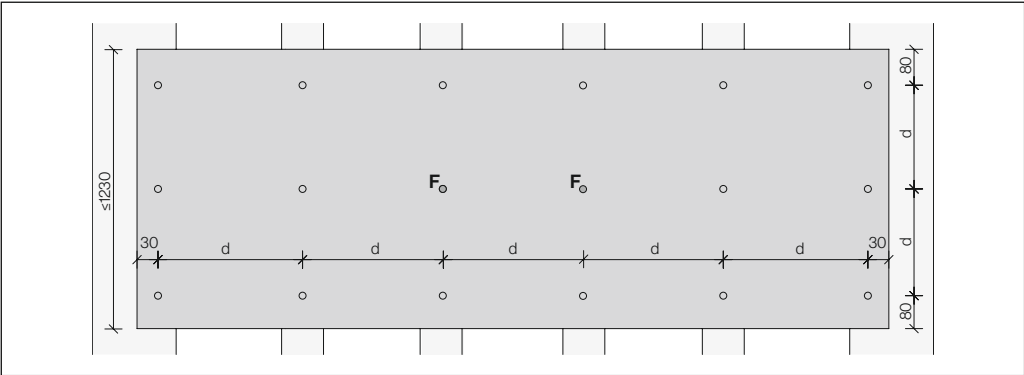

- Fixed point $\varnothing 9.5 \text{ mm [F]}$
- Slipping point $\varnothing 9.5 \text{ mm}$

Swisspearl stripes or Linearis

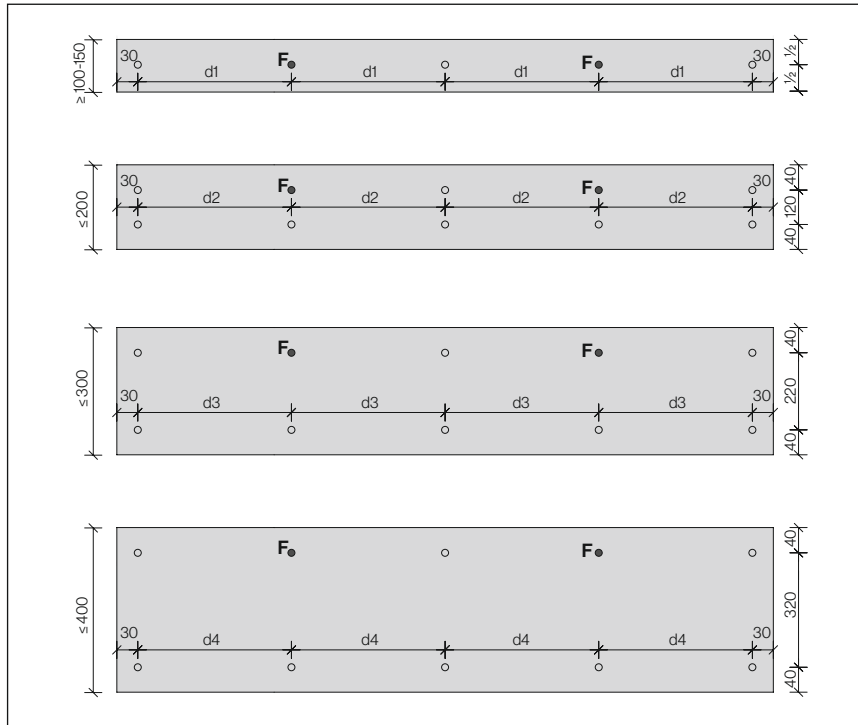

Fastener distances [d1-d4]

| | |
|-----------------------------|----------------------------|
| Wind load | $\leq 0.45 \text{ kN/m}^2$ |
| Building height up to (m) | ≤ 10 |
| Strip width 100-150 mm [d1] | 400 |
| Strip width ≤ 200 [d2] | 450 |
| Strip width ≤ 300 [d3] | 500 |
| Strip width ≤ 400 [d] | see page 19 |

Linearis panel strips are delivered without drill holes. Installation details as per this DIM are applicable.

- Fixed point $\varnothing 9.5 \text{ mm [F]}$
- Slipping point $\varnothing 9.5 \text{ mm}$

Swisspearl stripes or Linearis with open joints**Product**

Linearis are ready-made Swisspearl panel strips, for installing with open joints. Whether monochrome or multicolored, equal or varying format lengths, with continuous or offset joints – there is immense scope for different combinations.

Panel sizes Linearis

| | |
|---------------|----------------------------|
| 1500×147×8 mm | 4.37 Pieces/m ² |
| 2000×147×8 mm | 3.28 Pieces/m ² |
| 2500×147×8 mm | 2.63 Pieces/m ² |
| 1500×300×8 mm | 2.18 Pieces/m ² |
| 2000×300×8 mm | 1.64 Pieces/m ² |
| 2500×300×8 mm | 1.31 Pieces/m ² |

5 mm joints

Holes in panel for rivets

Fastener holes to be done at the jobsite. Diameter 9.5 mm.

Ventilation cavity

The min. cavity to be 40 mm with open joints.

Panel joints

Linearis typical panel joint is 5 mm, this allows panel scraps to be used as spacers. Wider joints will make any inaccuracies in the installation less noticeable.

Installation Reflex

When installed all the arrows to Reflex panels must point in one and same direction.

Fixed point for Aluminum Sub-frame

Fixed point for Aluminum, Type 8 diameter 9.4 mm [B/4]

- Rivet head diameter 15 mm 4.0×18-K15, blank or powder coated, grip range 8-13 mm.

Fixed point for Steel Sub-frame

Fixed point steel A2, Type 8, diameter 9.4 mm [B/4]

- SS Rivet, head diameter 15 mm, 4.0×18-K15, blank or powder coated, grip range 9-14 mm.

Drill holes diameter 4.1 mm to metal profiles

Use concenter drill gauge so that the holes will be concentric to the diameter 9.5 mm hole in the panel. Use drill bit type A for aluminum profiles and type S for steel.

Details

Installation details as per this DIM are applicable.

Vertical installation

The arrangement of Linearis is usually horizontal. For the execution of a vertical application please contact the Technical Service.

Linearis example

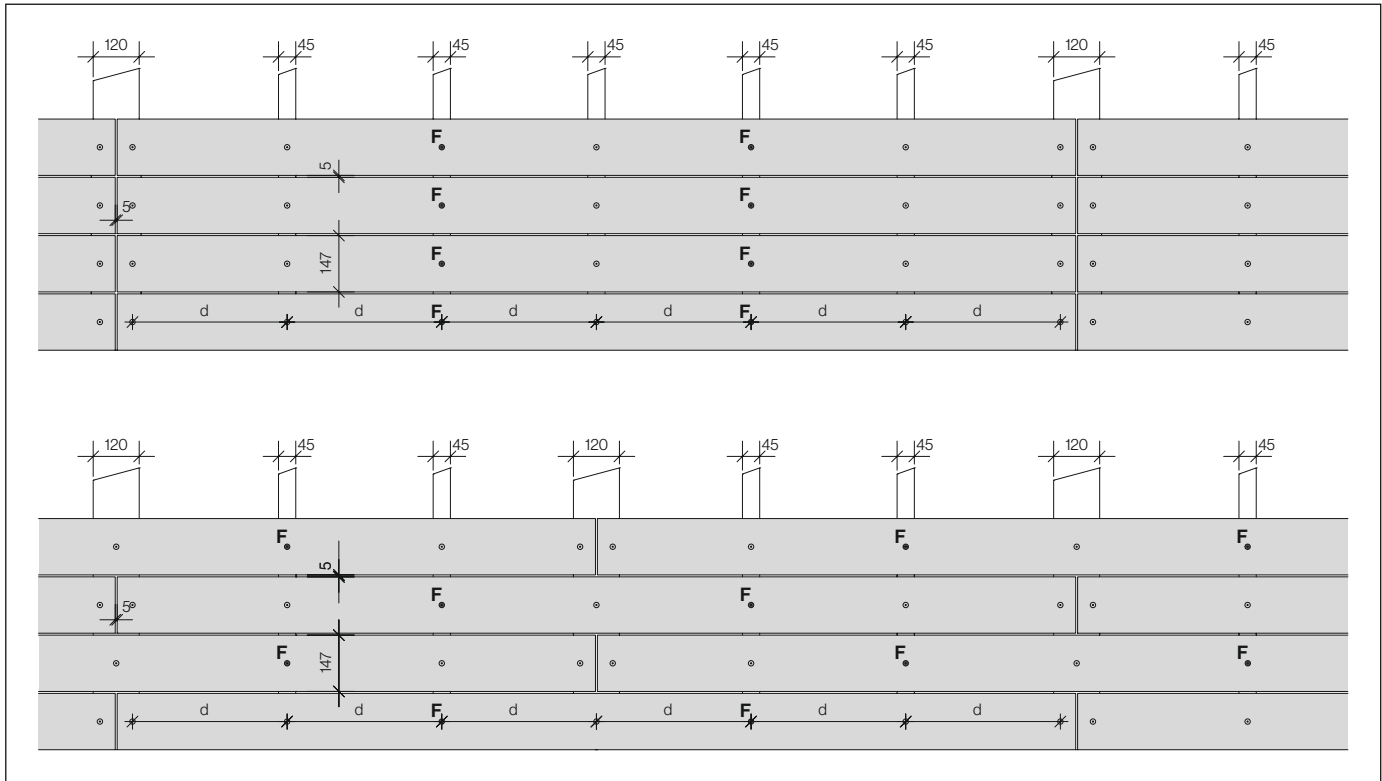

Attention! Staggered layout with centric T-profiles, the fastener hole is located in the center of the bracket.

- Fixed point Ø9.5 mm [F]
- Slipping point Ø9.5 mm

Example outer corner

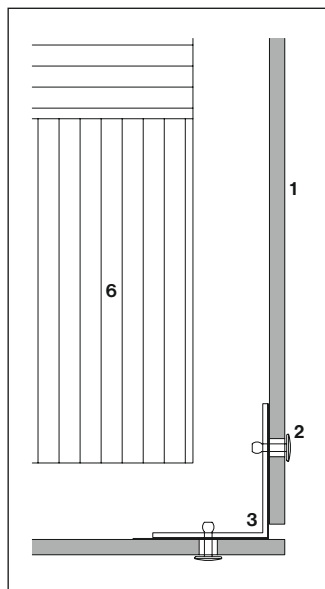

Example inner corner

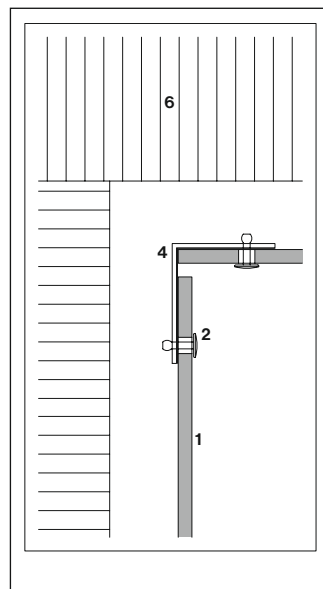
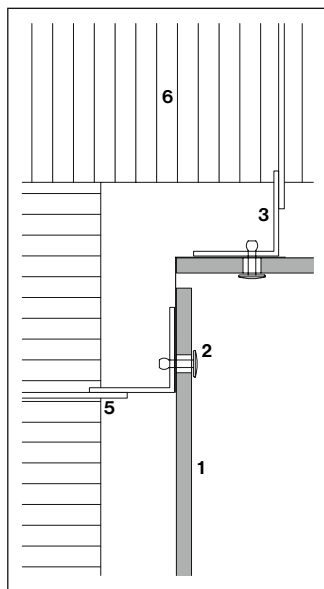

- 1 Swisspearl panel, 8 mm
- 2 Rivet 4.0x18-K15
- 3 Min. angle 60 x 60 mm
- 4 Min. angle 70 x 60 mm
- 5 Bracket
- 6 Thermal insulation

Corner angle not attached back to building as shown can be cantilevered up to 400 mm

Example window jamb

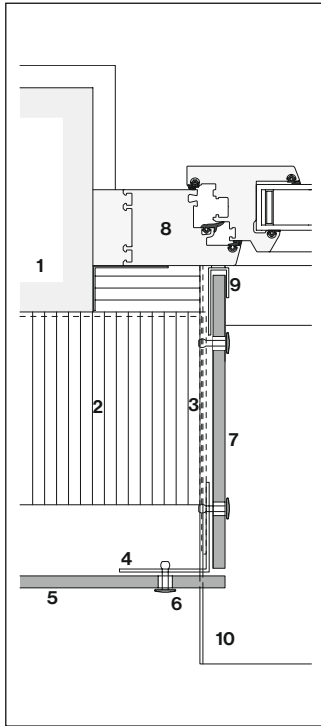

Jamb with 8 mm panel

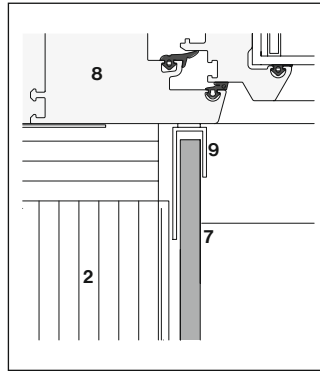

Window jamb with metal frame

- 1 Exterior wall
- 2 Thermal insulation
- 3 Horizontal support
- 4 Vertical support
- 5 Swisspearl panel 8 mm
- 6 Rivet 4.5x18 K15
- 7 Swisspearl jamb board 8 mm
- 8 Window frame
- 9 U or F-profile with sealant
- 10 Window sill

Example window sill

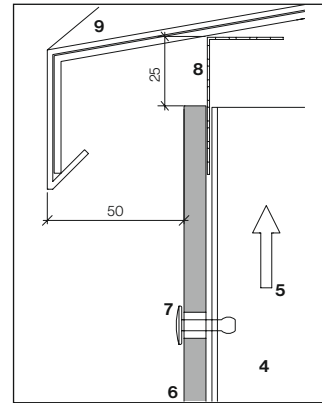
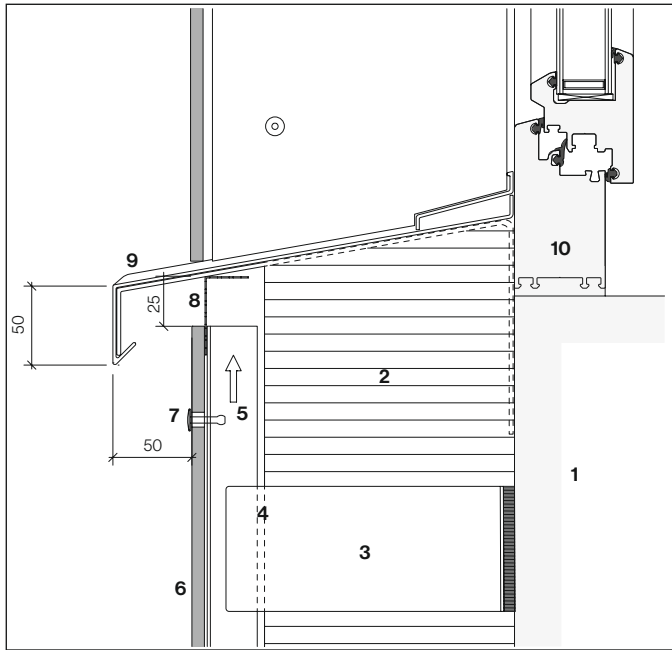

Sill detail

- 1 Exterior wall
- 2 Thermal insulation
- 3 Bracket
- 4 Vertical support
- 5 Ventilation cavity
- 6 Swisspearl panel 8 mm
- 7 Rivet 4.0×18-K15
- 8 Perforated angle
- 9 Window sill
- 10 Window frame

Window sill made of metal

Example window head

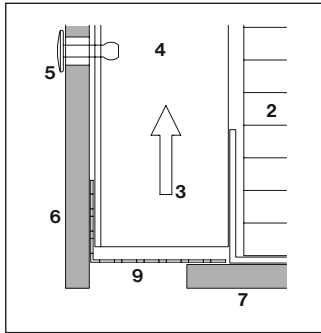

Perforated angle

- 1 Exterior wall
- 2 Thermal insulation
- 3 Ventilation cavity
- 4 Vertical support
- 5 Rivet 4,0x18-K15
- 6 Swisspearl panel 8 mm
- 7 Swisspearl panel 8 mm

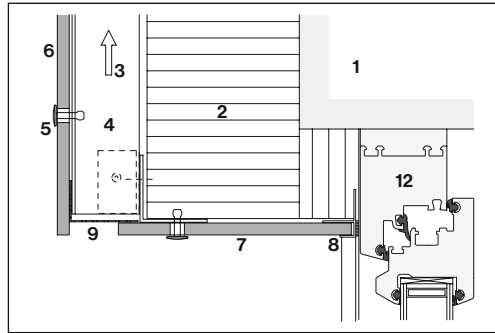

Metal framing around whole window

- 8 U or F-profile
- 9 Perforated angle
- 10 Reinforcing profile
- 11 Angle profile insulation
- 12 Window frame

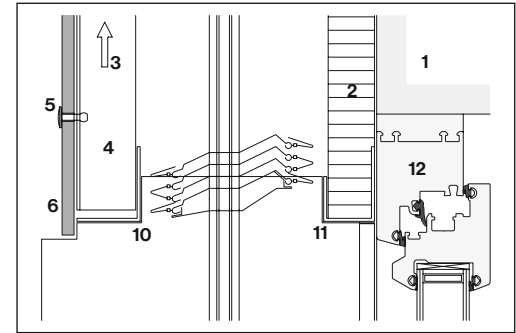

Head detail sun shutter

Example bottom detail

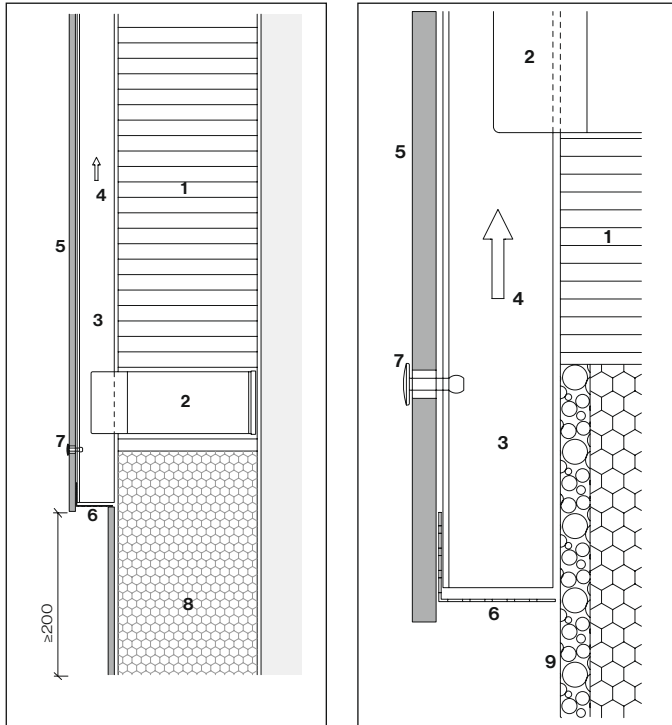

- 1 Thermal insulation
- 2 Bracket
- 3 Vertical support
- 4 Ventilated cavity
- 5 Swisspearl panel 8 mm
- 6 Perforated angle
- 7 Rivet 4.0x18-K15
- 8 Thermal insulation
- 9 Thermal insulation water resistant

In order to avoid damages its advised to keep a minimum distance of 200mm from bottom of the panel to the ground

Example coping detail

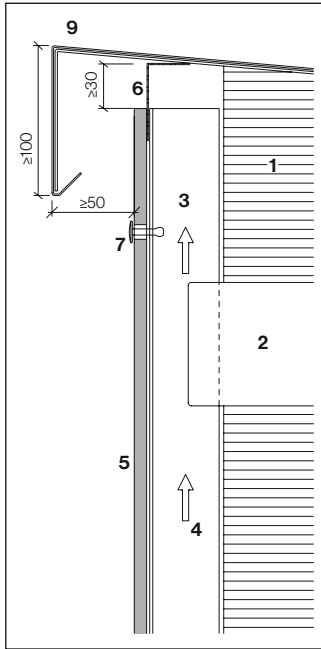

Coping detail

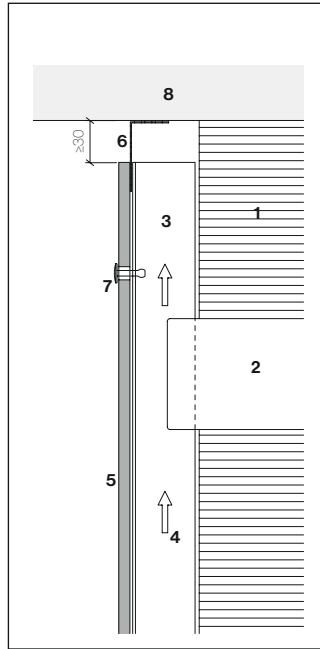

Details under slab

- 1 Thermal insulation
- 2 Bracket
- 3 Vertical support
- 4 Ventilated cavity
- 5 Swisspearlpanel 8 mm
- 6 Perforated angle
- 7 Rivet 4.0×18-K15
- 8 Soffit
- 9 Coping

Swisspearl screw

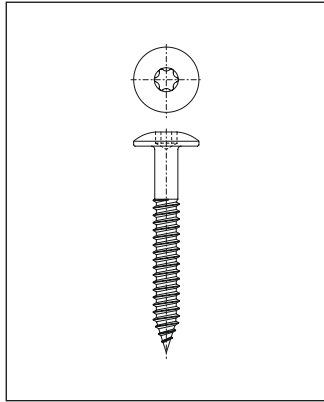

Swisspearl screw, stainless steel, saucer head Ø 12 mm, T20 drive, 4.8×38 mm.

Distances to panel edge

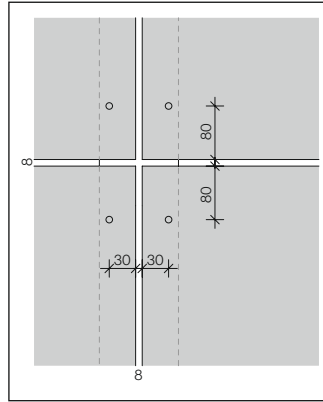

Panel hole

Diameter 5,5 mm

Standard edge distances

Horizontally 30 mm
Vertically 80 mm

Minimum edge distances

Horizontally 30 mm
Vertically 60 mm

Maximum edge distance

Horizontally and vertically max. 100 mm

Panel joints

Typical panel joint is 8 mm, this allows panel scraps to be used as spacers. Wider joints will make any inaccuracies in the installation less noticeable.

Installation

The screws must be installed with depth stop at 90 degrees set to the panel. The screw head must rest even to the panel.

Sub-frame engineering

Engineer / contractor are responsible for the design and installation of all sub framing parts including all pertaining fasteners.

Timber battens

Straight grown pine, dry (max. 20% moisture content).

Timber battens

Installation over timber battens is allowed provided the design meets local engineered codes and standards.

Timber quality

Battens must be thickness gauged to 1 face:

- Thickness min. 27 mm (min. 3/4")
- Always use planed surface timber
- Solidity class II (FK II/C24)
- Recommended only using kiln-dried lumber
- Moisture content max. 20-%

Vertical battens

At panel joints:

2 x 27 x 60 mm or

1 x 27 x 120 mm

Intermediate supports:

27 x 60 mm

Engineering

Battens including their attachment to be engineered per local standards.

Battens screw

Screw Ø min. 6 mm

Head Ø min. 12 mm

For battens wider than 60 mm use two screws per point of attachment. Rear ventilation, thermal insulation, moisture proofing, wind proofing layers. All local standards are applicable and must be complied with.

Joint flashing

Horizontal joint and L-flashing should be 2 mm shorter than panel and thus not visible in vertical joints. If required butt joint the flashings on any batten, do not overlap flashing.

L-flashings and horizontal joint flashing are not 100% water-proof! Therefore all timber battens must be fully covered by EPDM bands to protect them against moisture and to prevent rotting and the growth of fungi and mold.

EPDM strips

All timber battens must be fully covered by EPDM backing strips stapled to the battens. Stapled at the edges of the bands. EPDM strips to be in one single piece top to bottom or overlapped as per diagram.

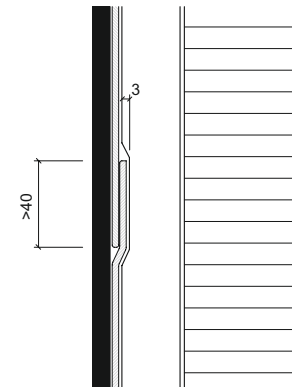

EPDM strip overlap

Horizontal panel joint

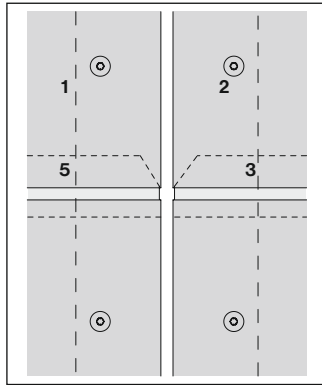
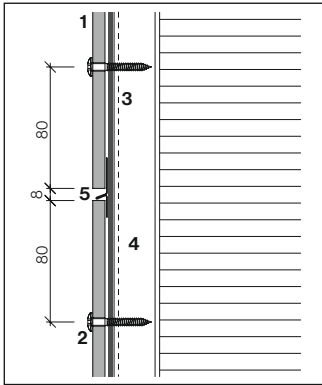

- 1 Swisspearl panel 8 mm
- 2 Screw
- 3a EPDM band 60 mm
- 3b EPDM band 120 mm
- 3c EPDM band 150 mm
- 4 Batten 27×60, 27×120 mm
- 5 Joint flashing

Horizontal section through vertical battens

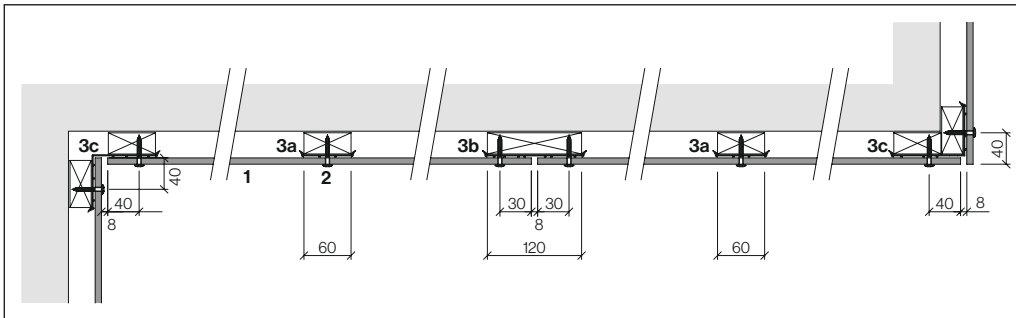

Vertical joint at window

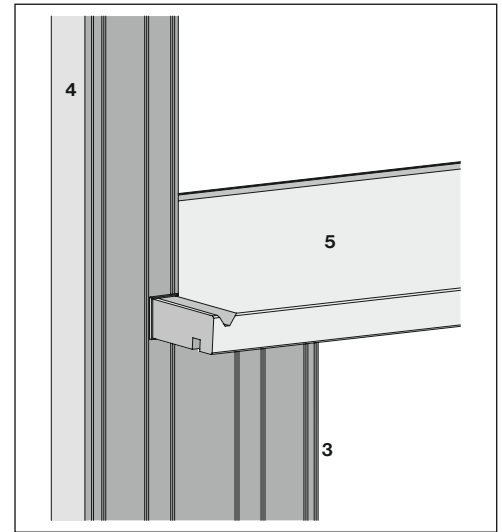
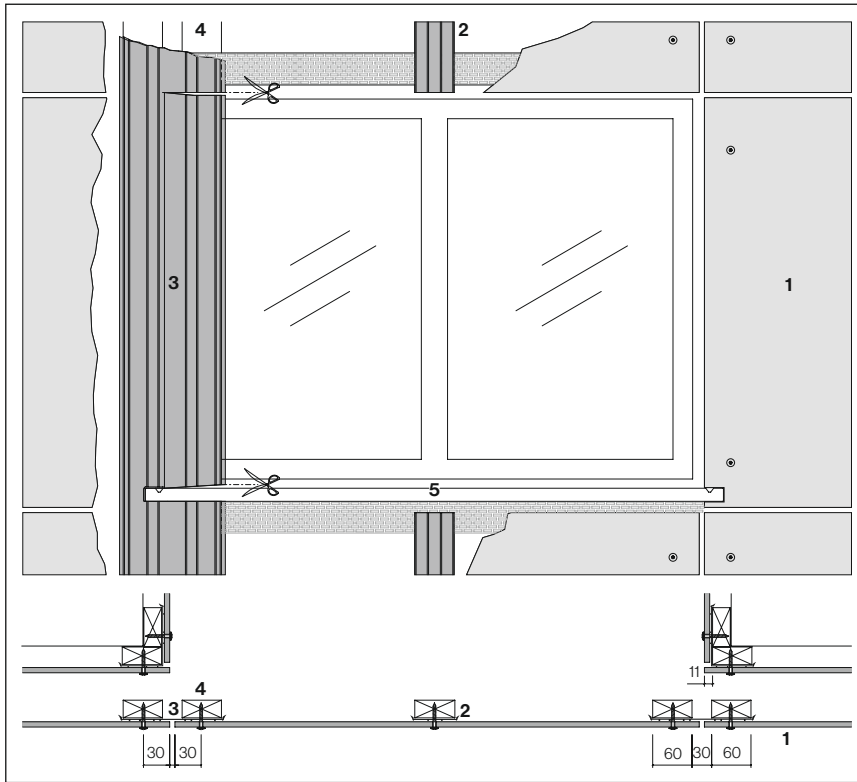

- 1 Swisspearl panel 8 mm
- 2 EPDM band 60 mm
- 3 EPDM band 150 mm
- 4 Batten 27×60 mm
- 5 Swisspearl window sill

Timber battens - 8 mm façade panels – screw distances

| Characteristic value of wind suction (according to European standards) | | Design value of wind suction (with a safety coefficient of 1.5) | | Spacing d (maximal distance between rivets) | | | |
|---------------------------------------------------------------------------------|--------|--------------------------------------------------------------------------|--------|---------------------------------------------|------------------|------------------------------|------------------|
| | | | | Vertical panel (portrait) | | Horizontal panel (landscape) | |
| kN/m ² | psf | kN/m ² | psf | horizontally mm | vertically mm | horizontally mm | vertically mm |
| -0.70 | -13.90 | -1.0 | -20.9 | 600 | 725 | 725 | 530 |
| -1.00 | -20.90 | -1.5 | -31.3 | 600 | 590 | 675 | 530 |
| -1.30 | -26.50 | -1.9 | -39.7 | 600 | 490 | 520 | 530 |
| -1.80 | -37.60 | -2.7 | -56.4 | 400 | 490 | 430 | 370 |
| -2.30 | -48.70 | -3.5 | -73.1 | 400 | 420 | 400 | 370 |
| -2.70 | -55.70 | -4.0 | -83.5 | 400 | 330 | 370 | 370 |
| -3.30 | -69.60 | -5.0 | -104.4 | 300 | 370 | 370 | 280 |
| -4.00 | -83.50 | -6.0 | -125.3 | 300 | 330 | 330 | 220 |

Above table is a guide line for 2 or more fasteners in vertical and horizontal direction. The spacings have been calculated considering a safety factor of 1.5. The spacings originate from 1230x3050 mm full size panels with equal distances between screws. Data may be interpolated.

Engineering responsibility

The spacings in above table are provided as indication. For the actual cladding design a locally licensed engineer shall assume responsibility for calculation and verification.

Panel data

- Modulus of elasticity
MOE ca. 15'000 MPa
- Modulus of rupture
(characteristic)
MOR (average) > 22 MPa
- Design value bending
resistance 8,0 MPa
(2,5 safety factor)
- Density > 1.75g/cm³

Design values

Resistance of screws 4.8x38 Ø 12 mm

| Position | Distance between fasteners (spacing) | | |
|----------|--------------------------------------|--------|--------|
| | 720 mm | 600 mm | 400 mm |
| Middle | 811 N | 961 N | 977 N |
| Edge | 515 N | 580 N | 665 N |
| Corner | 289 N | 362 N | 445 N |

The data was evaluated according to ETAG 034 using 8 mm panel, and includes a safety factor of 2.5. Diameter of panel hole must be 5.5 mm, and screw head must be 12 mm. Minimum screw engagement in timber to be 27 mm. Edge distances 30 mm horizontally, 80 mm vertically. The data may be interpolated.

Timber battens - 12 mm façade panels – screw distances

| Characteristic value of wind suction (according to European standards) | | Design value of wind suction (with a safety coefficient of 1.5) | | Spacing d (maximal distance between rivets) | | | |
|---------------------------------------------------------------------------------|----------|--------------------------------------------------------------------------|----------|---------------------------------------------|------------------|------------------------------|------------------|
| kN/m ² | psf | kN/m ² | psf | Vertical panel (portrait) | | Horizontal panel (landscape) | |
| | | | | horizontally mm | vertically mm | horizontally mm | vertically mm |
| 2.23 | 46.64 | 3.35 | 69.97 | 530 | 725 | 725 | 530 |
| -3.00 | - 62.65 | - 4.50 | - 93.99 | 530 | 580 | 580 | 530 |
| -3.83 | - 80.05 | - 5.75 | - 120.1 | 530 | 465 | 465 | 530 |
| -4.24 | - 88.55 | - 6.36 | - 132.84 | 530 | 420 | 420 | 530 |
| -5.97 | - 124.74 | - 8.96 | - 187.14 | 350 | 465 | 465 | 350 |
| -6.95 | - 145.07 | - 10.42 | - 217.64 | 350 | 410 | 410 | 350 |
| -7.96 | - 166.23 | - 11.94 | - 249.39 | 350 | 365 | 365 | 350 |
| -9.00 | - 187.95 | - 13.50 | - 281.97 | 350 | 325 | 325 | 350 |

Above table is a guide line for 2 or more fasteners in vertical and horizontal direction. The spacings have been calculated considering a safety factor of 1.5. The spacings originate from 1230x3050 mm full size panels with equal distances between screws. Data may be interpolated.

Engineering responsibility

The spacings in above table are provided as indication. For the actual cladding design a locally licensed engineer shall assume responsibility for calculation and verification.

Panel data

- Modulus of elasticity
MOE ca. 15'000 MPa
- Modulus of rupture
(characteristic)
MOR (average) > 22 MPa
- Design value bending
resistance 8,0 MPa
(2,5 safety factor)
- Density > 1.75g/cm³

Design values

Resistance of screws 4.8x44 Ø 12 mm

| Position | Distance between fasteners (spacing) | | |
|----------|--------------------------------------|----------|-----------|
| | 180 mm | 270 mm | 350 mm |
| Middle | 2474 N | 1993.6 N | 1774.24 N |
| Edge | 1688.4 N | 1387.2 N | 1232.4 N |
| Corner | 1360.4 N | 901.6 N | 723.6 N |

The data was evaluated according to ETAG 034 using 8 mm panel, and includes a safety factor of 2.5. Diameter of panel hole must be 5.5 mm, and screw head must be 12 mm. Minimum screw engagement in timber to be 27 mm. Edge distances 30 mm horizontally, 80 mm vertically. The data may be interpolated.

Single span panel (no intermediate support)

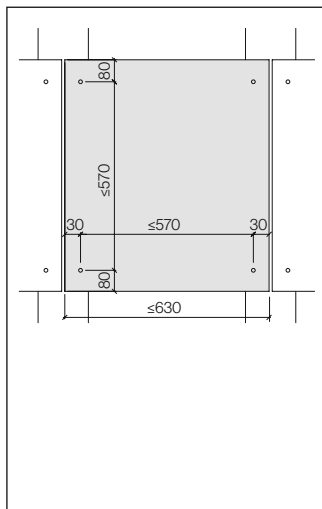
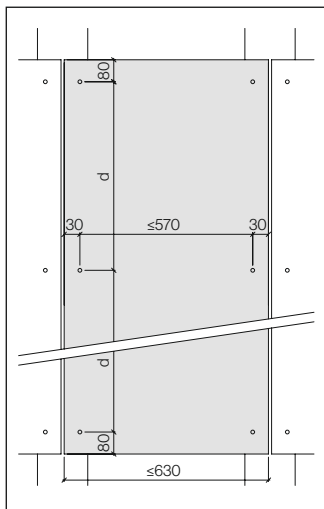

Soffit panels

Fastener distances for soffit panels and suspended ceilings not to exceed 500mm.

Max. distance between fasteners for single span panels 570 mm, unless smaller distance is required by high wind load as per table of fastener distances.

Vertical panel (portrait)

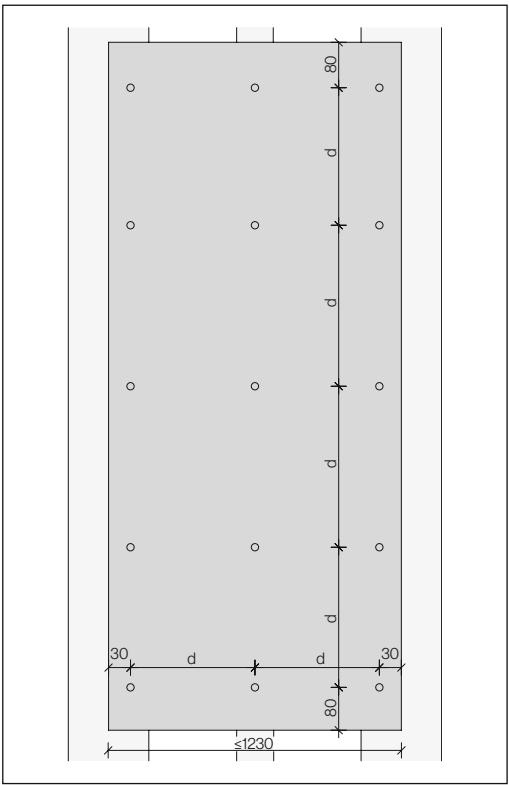

Horizontal panel (landscape)

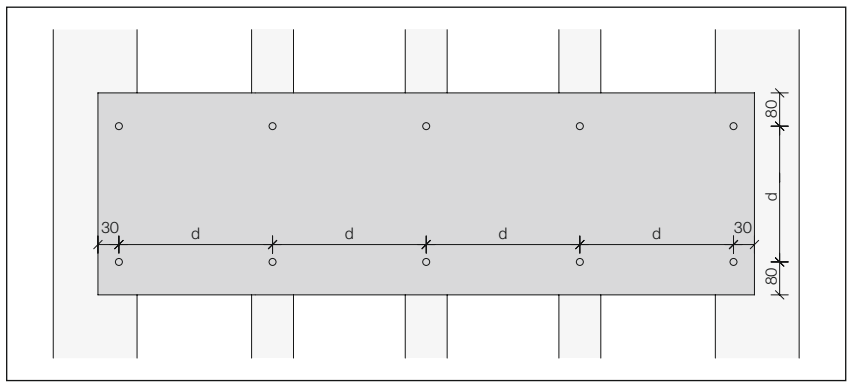
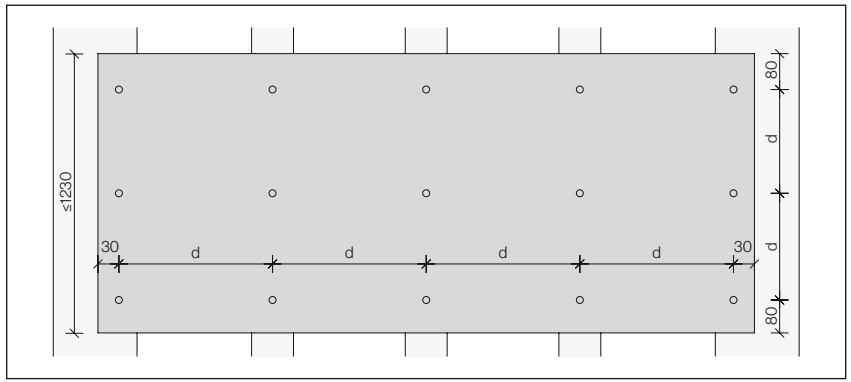

Drill holes $\varnothing 5.5$ mm

Swisspearl strips or Linearis

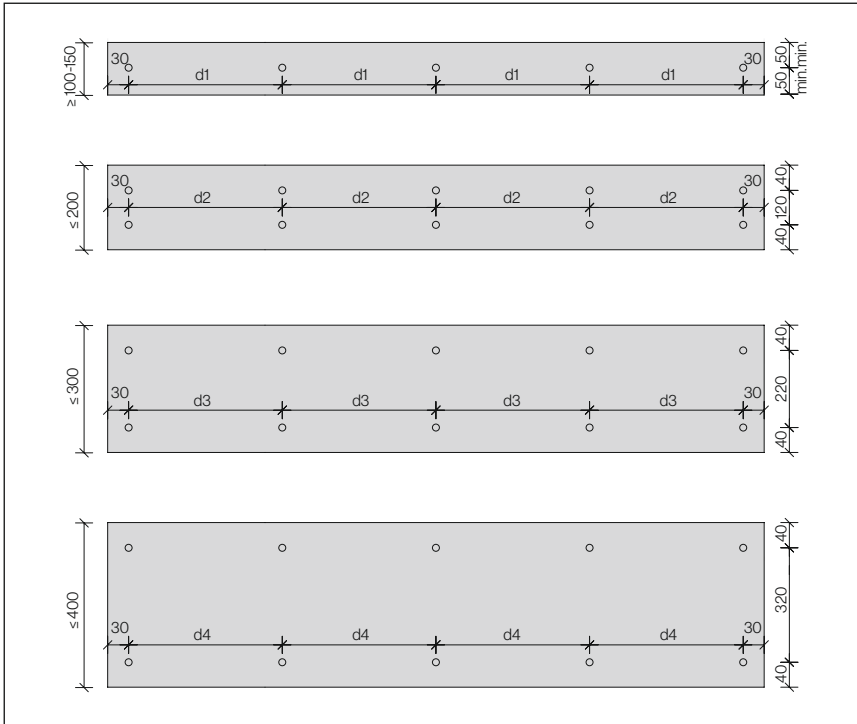

Fastener distances [d1-d4]

| | |
|-----------------------------|--------------------------|
| Wind load | ≤ 0.45 kN/m ² |
| Building height up to (m) | ≤ 10 |
| Strip width 100-150 mm [d1] | 400 |
| Strip width ≤ 200 [d2] | 450 |
| Strip width ≤ 300 [d3] | 500 |
| Strip width ≤ 400 [d4] | see page 40 |

Swisspearl Stripes or Linearis with open joints

Product

Linearis are ready-made Swisspearl panel strips, for installing with open joints. Whether monochrome or multicolored, equal or varying format lengths, with continuous or offset joints – there is immense scope for different combinations.

Panel sizes Linearis

| | |
|---------------|----------------------------|
| 1500×147×8 mm | 4.37 Pieces/m ² |
| 2000×147×8 mm | 3.28 Pieces/m ² |
| 2500×147×8 mm | 2.63 Pieces/m ² |
| 1500×300×8 mm | 2.18 Pieces/m ² |
| 2000×300×8 mm | 1.64 Pieces/m ² |
| 2500×300×8 mm | 1.31 Pieces/m ² |

5 mm joints

Holes in panel for screws

Fastener holes to be done at the jobsite. Diameter 5.5 mm.

Ventilation cavity

The min. cavity to be 40 mm with open joints.

Panel joints

Linearis typical panel joint is 5 mm.

Installation Reflex

When installed all the arrows to Reflex panels must point in one and same direction.

Timber battens

Installation over timber battens is allowed provided the design meets local engineered codes and standards.

EPDM strips

All timber battens must be fully covered by EPDM backing strips stapled to the battens. Stapled at the edges of the bands. EPDM strips to be in one single piece top to bottom or overlapped.

Mandatory the use of Swisspearl EPDM bands with side lips

Details

Installation details as per this DIM are applicable.

Vertical installation

The arrangement of Linearis is usually horizontal. For the execution of a vertical application please contact the Technical Service.

Vertical battens

Under butt joint 1×40×120 mm or 2×40×60 mm, one-sided planed. Intermediate support 40×60 mm, one-sided planed.

Linearis example

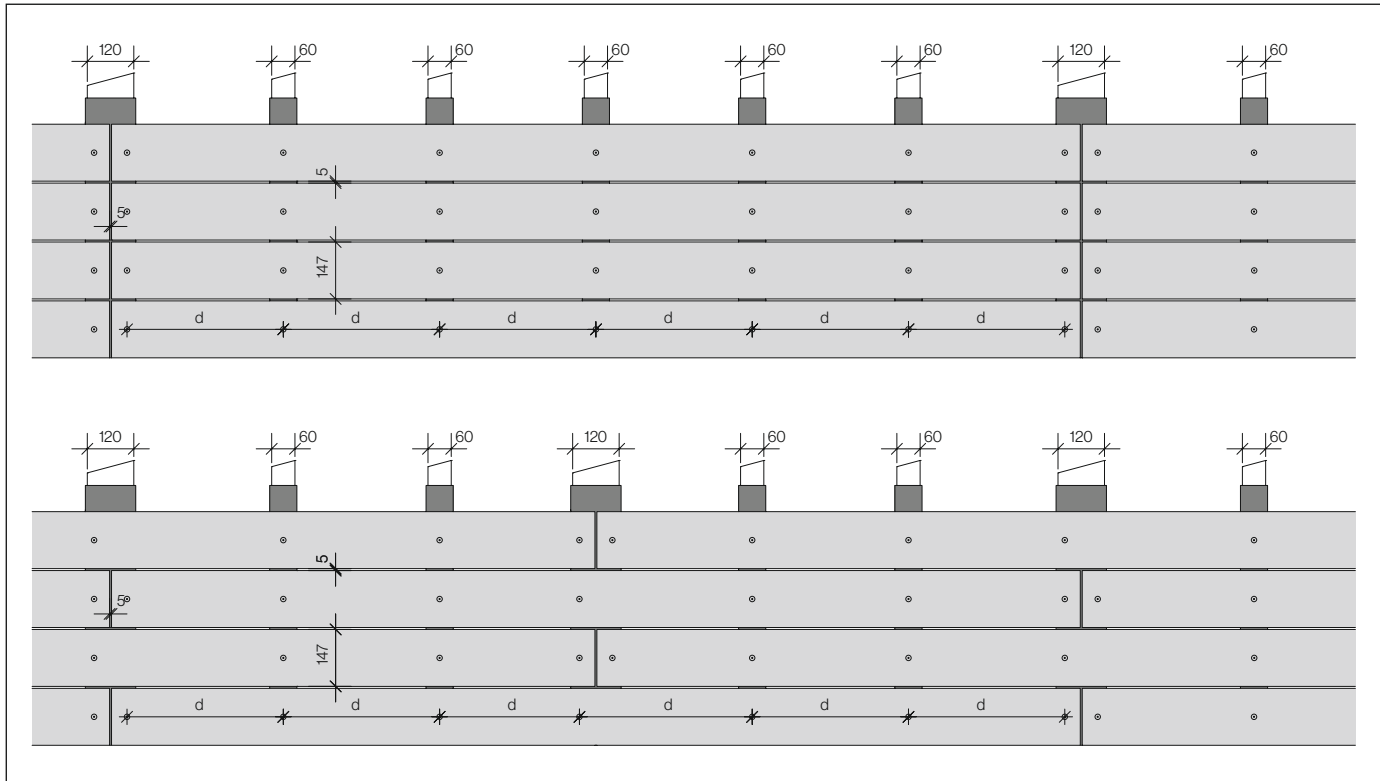

By an offset configuration, fastener hole not to be placed at the joint axis (water course).

Linearis example outer corner

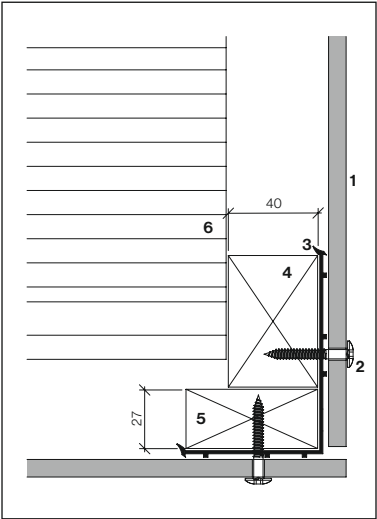

Batten configuration to building corner as shown above with the use of 150 mm EPDM.

Linearis example inner corner

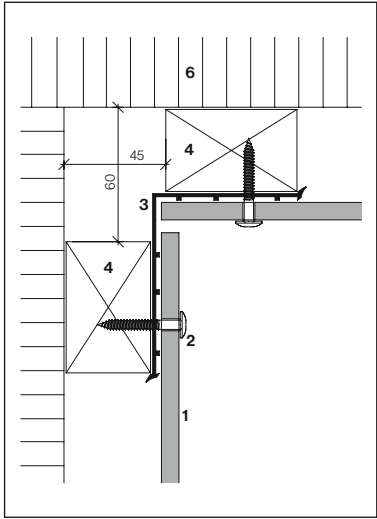

- 1 Linearis 8 mm
- 2 Swisspearl Screw 4.8x38 mm
- 3 EPDM band 150 mm
- 4 Batten 40x60 mm
- 5 Batten 27x60 mm
- 6 Thermal insulation

Swisspearl example outer corner

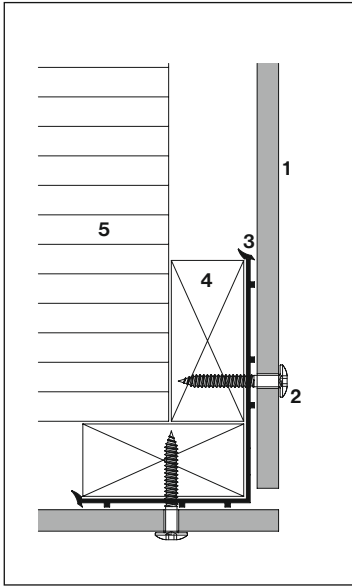

Swisspearl example inner corner

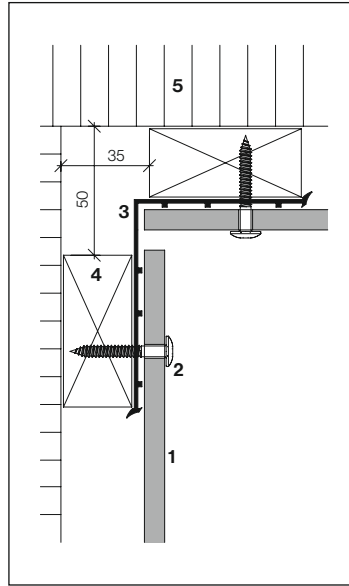

- 1 Swisspearl 8 mm
- 2 Swisspearl Screw 4.8×38 mm
- 3 EPDM band 150 mm
- 4 Batten 27×60 mm
- 5 Thermal insulation

Batten configuration to building corner as shown above with the use of 150 mm EPDM.